

218 Bobcat



True-Line Series



240 and 240XL Series



True-Line SR Series

Micro-Perforation Heads

ROSBACK

Rosback has been providing world class perforating, creasing, and slitting solutions since 1881. The TrueLine and 240XL series perforators provide quality, cost-effective perforating and creasing solutions that presses or folders cannot match. No wonder thousands of demanding print finishers ask for ROSBACK

Now add the Micro-Perforation Heads to your ROSBACK perforator/creaser. Rosback Micro-Perforation is designed to produce consistent miniature perforations into stock. A ream of micro perforated stock will remain flatter than slot-cut or knife-cut perforated stock. Choose from 36, 54, or 72 teeth to the inch.

EASY SETUP & OPERATION:

- Locate the upper head's line of perforation and lock into position.
- Position the lower head so that the perforation line is centrally located over the lower head's outer steel ring. Lock the lower head into position.
- Lower the upper head by rotating the pitch lever to #3 and place a sheet between the upper & lower heads.
- Lower the shaft in small increments while turning the hand wheel until a line appears on the sheet. Remove the sheet with the hand wheel and observe the perforation line.
- Check the perforation line for the desired depth. Lowering the upper shaft will create more pressure producing a deeper, more pronounced perforation line.

Micro Perforation Heads

Available Kits:

220-A-118 36 TPI Kit
220-A-110 54 TPI Kit
220-A-111 72 TPI Kit
-All kits include:
220-A-075 -Burr Roller
220-A-073 -Micro Perf Lower Head
And Corresponding Upper Head

OTHER AVAILABLE ACCESSORIES FOR ROSBACK PERFORATORS:

- TrueScore System. Eliminates cracking on all sensitive and delicate materials.
- Slot-Cut Heads. Produce a clean, highly visible and attractive line of perforation in 3 to 12 tpi.
- Knife-Cut Heads. Produce a clean, nearly invisible line of perforation in 3 to 12 tpi.
- Micro-Perf Heads. Very popular for refeeding printers. Produce a flat, strong perforation that leaves an exceptionally clean edge after separation. Available in 54 or 72 tpi.
- Slitting Heads. Cut multiple forms apart while you crease and slit.
- Scoring Heads. Many varieties in stock. Ask us if you have special needs.
- "CD" Inlay Heads. Produce finished CD inlay cards in single or multiple formats.
- Gutter Slit/Perf Heads. Slit apart multiple format jobs while ejecting the scrap strip away from the finished pieces.
- Pressure-Sensitive Slitting Attachment. Backslit or semi-slit labels and decals.
- Narrow Margin Perf Heads (3/8" From Sheet Edge)
- Special Slot-Perf Heads (1/2" Between Perf Lines)
- Special Engineered Heads. Let us know your needs. We have probably done it before and can produce your special application head quickly, saving you time and money.

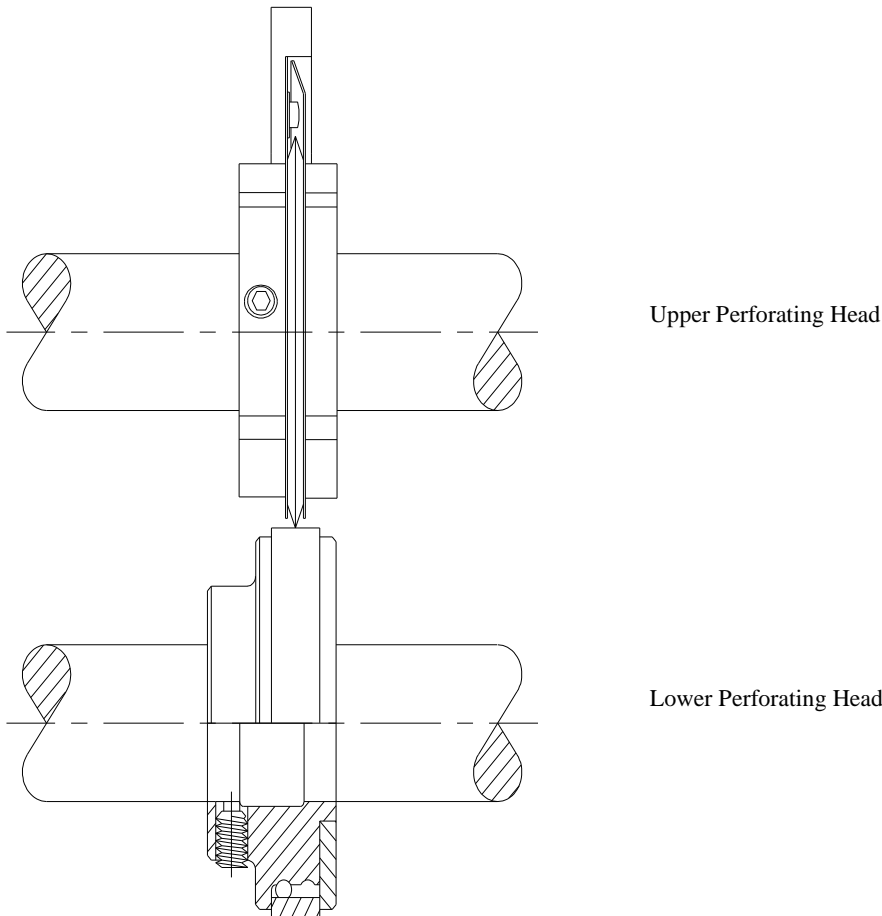

ROSBACK CO.

125 HAWTHORNE AVE., ST. JOSEPH, MI 49085 USA
Phone: (269) 983-2582 * Fax: (269) 983-2516
Internet: www.rosbackcompany.com * E-mail: Sales@RosbackCompany.com

Your Dealer: