

ROSBACK COMPANY

Manufacturer of Quality Handcrafted Bindery & Finishing Equipment since 1881

MICRO PERFORATING INSTRUCTIONS

Rosback micro perforating is designed to produce consistent miniature perforations into stock. No material is removed because the perforations are pressed into the stock. Micro perforating is primarily used for laser printers. However, there is a multitude of uses for micro perforated stock in the printing industry. A ream of micro perforated stock will remain reasonably flat, much flatter than slot-cut or knife-cut perforated stock.

The 54-tooth blade is generally for thicker and more fibrous stock. The 72-tooth blade is generally for thinner less fibrous stock. Special made-to-order blades are available upon request, contact Rosback for more info.

Rosback recommends that only one micro perforating assembly be used on the model 220 and 218 Perforators. All other Rosback perforators can use up to four micro perforating assemblies. Extra shaft supports and drive rollers will be required for more than two micro perforating assemblies.

Micro perforating and scoring simultaneously:

To micro perforate and score simultaneously, setup the micro perforation first. Make a note of the depth setting. Now, position the scoring heads. Try each of the three grooves available in the lower head at the micro perforating depth previously established. Choose the groove that gives the most desirable score and lock the scoring heads.

Using other tooling simultaneously:

Micro perf can be used along with regular slot-cut and knife-cut perforating as well as slitting and pressure sensitive slitting.

Rosback suggests that if heavy thick stock is to be micro perforated then test samples should be done to assess the quality and practicality of micro perforating thick stock.

For successfully micro perforating, a rough guide is provided below of materials that should be considered as the maximum material weights.

Tips for best blade life:

- Do not run any perforator without feeding stock while heads are engaged.
- Always raise the upper shaft when not operating the perforator. This relieves the pressure off the blade teeth and lower head's internal rubber ring. Make a note to each optimal job setting.
- For models 240, 242 and 243 perforators reduce the gap to smallest possible between sheets.
- Remember the greater the depth of micro perforation the lesser the blade life.

Micro Perf Kits & Replacements	Part #
36 Teeth Per Inch Micro-Perf Kit	220-A-118
54 Teeth Per Inch Micro-Perf Kit	220-A-110
72 Teeth Per Inch Micro-Perf Kit	220-A-111
Replacement Blade 36tpi	240-297-36
Replacement Blade 54tpi	240-297-54
Replacement Blade 72tpi	240-297-72
Micro perforating kits contain one upper head with blade, one lower head and a post-perforation roller.	

Stock weight	Stock type
110lbs (199gsm)	Index or postcard
80lbs (216gsm)	Text
80lbs (216gsm)	Cover
100lbs (199gsm)	Offset
10pt	Cover

ROSBACK COMPANY

Manufacturer of Quality Handcrafted Bindery & Finishing Equipment since 1881

MICRO PERFORATING INSTRUCTIONS (Cont.)

Setup Instructions:

1. Loosen the upper & lower cutter shafts and slide them out allowing enough space to slip the upper & lower micro perforating heads onto their respective shafts. Then, return shafts and accessories into place.
2. Locate the upper head's line of perforation and lock into position.
3. Position the lower head so that the perforation line is centrally located over the lower head's outer steel ring. Lock the lower head into position.
4. Lower the upper head by rotating the pitch lever to #3 and place a sheet between the upper & lower heads.
5. Very carefully, lower the shaft in small increments while turning the hand wheel and look at the sheet exiting the micro perf heads. When a line appears on the sheet stop rotating the pitch lever.
6. Completely remove the sheet with the hand wheel and observe the perforation line.
7. Turn the machine on and automatically feed one sheet. Check the perforation line for the desired depth. Lowering the upper shaft will create more pressure producing a deeper, more pronounced perforation line.

IMPORTANT NOTE: When micro perf heads are not operating, always completely raise the pitch lever. Disengaging micro perf heads will considerably increase the cutter life and the lower head internal ring.

Maintenance Instructions:

To replace the upper cutter blade, see drawing. In the event that your lower micro perf head is running concentrically (or out of round) you may need to re-lubricate or replace your lower head's internal ring. Perform this task by following these steps:

1. Remove the retainer ring fastening screws.
2. Remove the outer steel ring and internal rubber ring.
3. Lightly lubricate the rubber ring and groove with Dow Corning Compound 111 Valve lubricant & Sealant. (Or obtain some dielectric grease from your local automotive parts supply store)
4. Place the rubber ring into the groove next to the shoulder. Insert a toothpick between the rubber ring and hub. Circle the toothpick around the hub two or three times and then release it. This will ensure that the rubber ring is properly seated and not twisted in the groove.
5. Lightly lubricate the inside diameter of the outer ring.
6. Carefully re-assemble the outer steel ring by gently twisting and lightly pushing the steel ring onto and over the rubber ring until it is against the shoulder. DO NOT forcefully push straight over the rubber ring. Possible damage and dislocation may occur if the outer ring is pushed straight over the rubber ring.
7. Re-assemble the outer retainer ring.

Shipping & Mailing Address: 125 Hawthorne Ave., St. Joseph, MI 49085

Phone: (269) 983-2582 * Fax: (269) 983-2516 * Internet: www.rosbackcompany.com * E-mail: rosbacksales@qtm.net

Manufactured in the USA since 1881

ROSBACK COMPANY

Manufacturer of Quality Handcrafted Bindery & Finishing Equipment since 1881

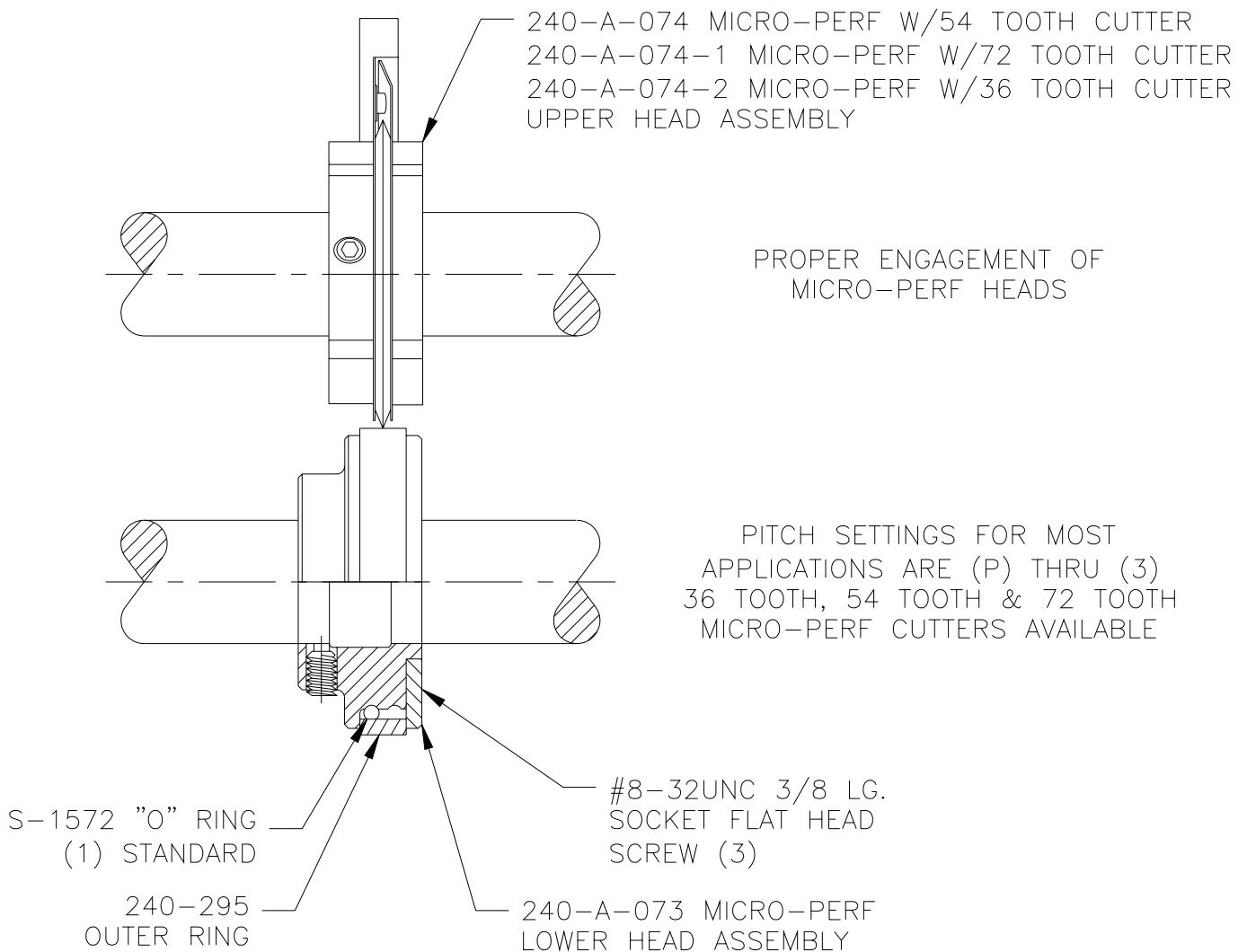

Replacement Cutter Part # 240-297-36 36 MICRO PERFORATIONS PER INCH

Replacement Cutter Part # 240-297-54 54 MICRO PERFORATIONS PER INCH

Replacement Cutter Part # 240-297-72 72 MICRO PERFORATIONS PER INCH