

ROSBACK COMPANY

Manufacturer of Quality Handcrafted Bindery & Finishing Equipment

KNIFE SHARPENING SHEET

The illustration below gives the dimensions and instructions for sharpening the knives. Although knives do not need to be sharpened in pairs or all at once, it is more practical to replace the entire set at one time. The scissors action of the knives provides a better cut and self-sharpening tendencies, extending their useful life between sharpenings.

WARNING: Use Extreme Caution! DO NOT handle or touch dull knives with bare hands. Always use 250-302 Upper Knife Holder when handling this knife. Dull trimming knives are still extremely sharp.

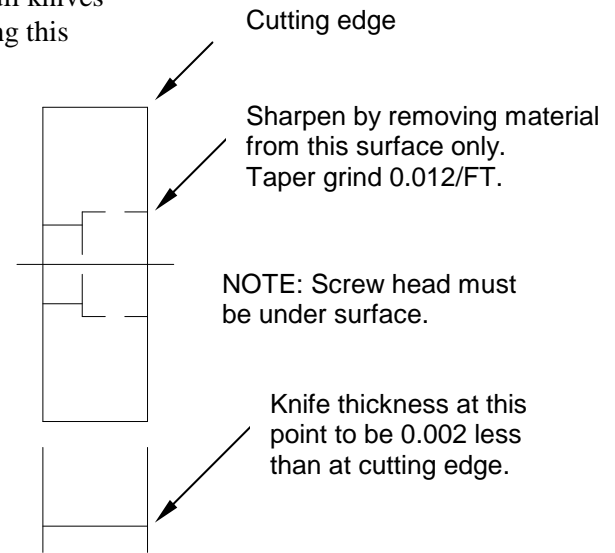
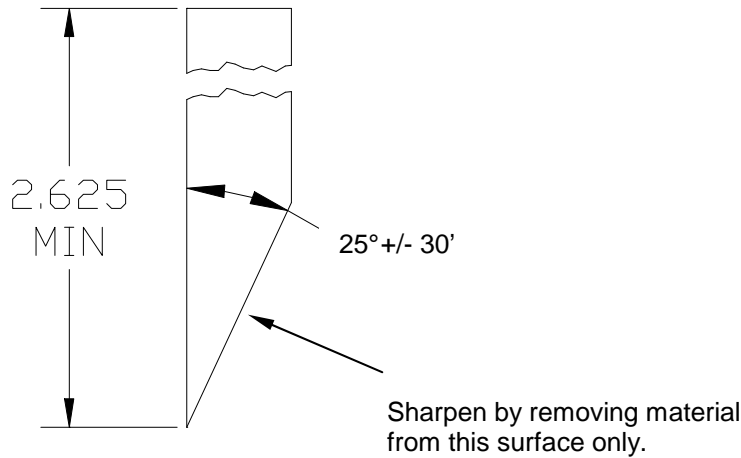

NOTE: To maintain the correct upper knife angle, set the LH Side Knife setscrews to the dimensions shown below. Remember, the left hand side is defined as being on your left when you are facing the front knife with books on the infeed table moving away from you.

Set the RH Side Knife and the Front Knife setscrews the opposite of that shown below.

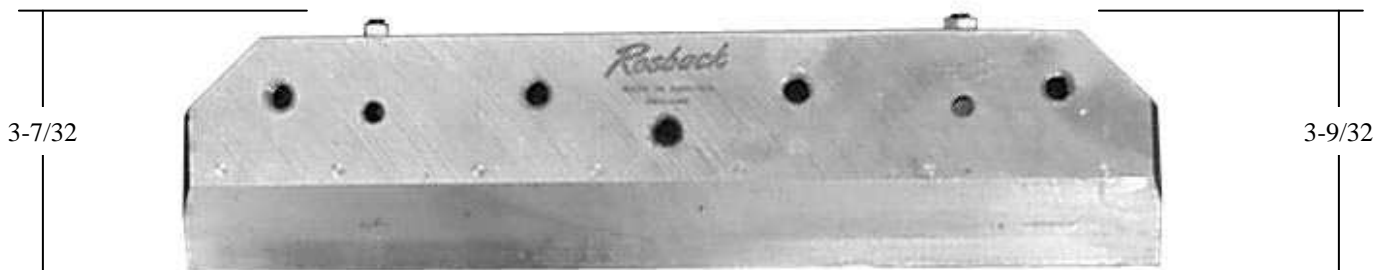

Shipping & Mailing Address: 125 Hawthorne Ave., St. Joseph, MI 49085
Phone: (269) 983-2582 * Fax: (269) 983-2516 * Internet: www.rosbackcompany.com * E-mail: Sales@RosbackCompany.com
Manufactured in the USA since 1881