



930XL Conveyor Delivery

ROSSBACK

Designed for runs of hundreds and thousands... built for thousands of runs.

The 930XL Conveyor Delivery is a large 30" belt conveyor that is a perfect option to work with any Rosback Trueline, SR-Series or 240XL Series Perforating or Slitting machine. It raises, lowers and pivots to any desired angle. This conveying unit can also operate with any other finishing equipment in the industry that requires continuous shingle delivery.

This self-powered conveyor plugs into any standard 115VAC socket and features infinite variable speed control up to 25,000 FPH. Stop and Start Feed Controls and Emergency Stop push button are standard when connected to a Rosback Perforator. Specialized controls are available for other applications. Contact the factory or your Rosback dealer for details.

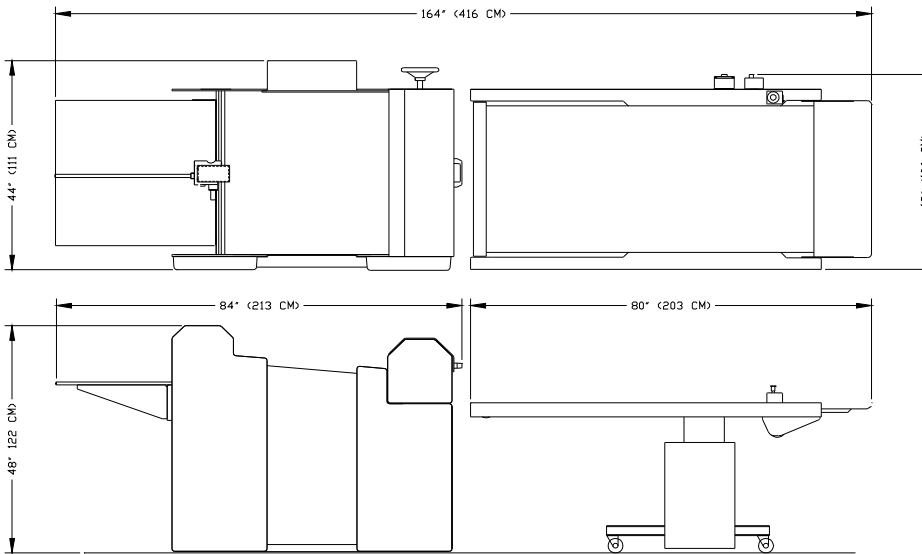

As shown with 240XL Perforator

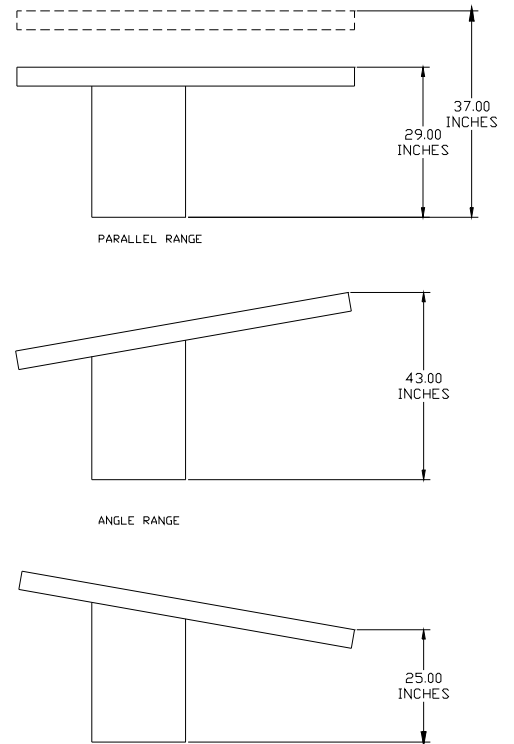

930XL CONVEYOR DELIVERY SPECS

Minimum Sheet Size	3" (7.6 cm) x 3" (7.6 cm)
Maximum Sheet Size	30" (76.2 cm) x 30" (76.2 cm)
Cycle Speed	Up to 25,000 Feet per hour
Machine Dimensions	L: 80" (203cm); W: 42" (106cm) H: 37" (94cm)
Parallel Height Range	High: 37" (94cm) ; Low: 29" (73cm)
Angular Pivot Height Range	High: 43" (109cm) ; Low: 25" (63cm)
Net Weight	350 lbs. (160 kg)
Shipping Weight	545 lbs. (247 kg)
Standard Input Power	115V 60Hz 15AMP

*Contact Rosback for alternate electrical requirements
 Design Specifications Subject To Change Without Notice

ROSBACK CO.

125 HAWTHORNE AVE., ST. JOSEPH, MI 49085 USA
 Phone: (269) 983-2582 * Fax: (269) 983-2516
 Internet: www.rosbackcompany.com * E-mail: Sales@RosbackCompany.com

Your Dealer: