

ROSBACK COMPANY

Manufacturers of Quality Handcrafted Bindery & Finishing Equipment since 1881

Instructions for converting STAGGER STICH to STRAIGHT STITCH On Rosback Model 201 Stitchers

RECOMMENDED TOOLS:

Allen wrench set

1. Looking at the rear of the machine, open the right-hand rear panel. Jog the machine until the stagger stitch pin (1) is aligned in the upright position.
2. **WARNING!** Disconnect 201 Stitcher from power supply.
3. Loosen the setscrew above the stagger stitch pin (1) in the knurled hub (2) and remove pin.
4. Turn the knurled hub clockwise so the right-hand hole in the sprocket is aligned with the hub setscrew hole.
5. Reinsert the stagger stitch pin through the sprocket and hub.
6. Tighten the setscrew in the hub to secure the pin.
7. Reattach the rear guarding.
8. Reconnect power to the 201 Stitcher and check that the feed fingers are sliding to the same position every stroke.

NOTE: To convert straight stitch back to stagger stitch, follow steps one through three. For step four, turn the knurled hub counterclockwise so the left-hand hole in sprocket aligns with the hub setscrew hole. Follow the remaining steps five through eight. In step eight, the feed fingers should slide to the same position every other stroke.

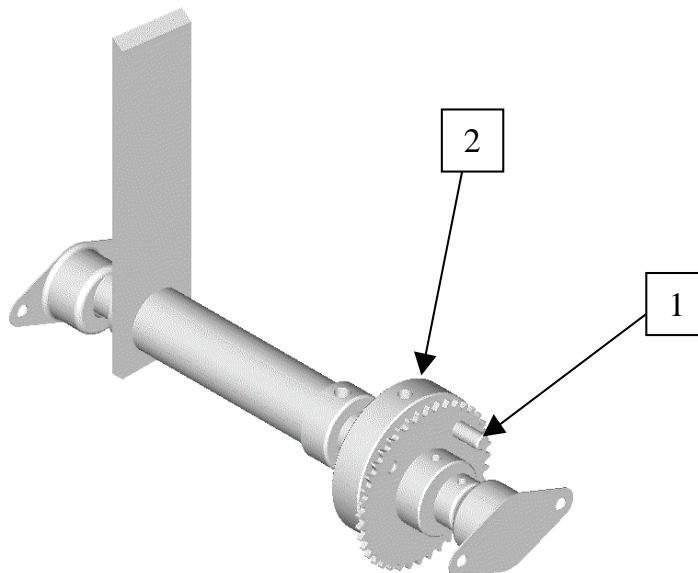

Shipping & Mailing Address: 125 Hawthorne Ave., St. Joseph, MI 49085

Phone: (269) 983-2582 * Fax: (269) 983-2516 * Internet: www.rosbackcompany.com * E-mail: Sales@RosbackCompany.com

Manufactured in the USA since 1881