

ROSBACK

PRINTERS AND BOOKBINDER'S MACHINERY

Quality Bindery Equipment Since 1881

ASSEMBLY INSTRUCTIONS & SPARE PARTS LIST MANUAL

**Models: 126 and 139
Stock Trucks**



Shipping & Mailing Address: 125 Hawthorne Ave., St. Joseph, MI 49085 USA
Phone: (269) 983-2582 * Fax: (269) 983-2516 * Internet: www.rosbackcompany.com * E-mail:
Sales@RosbackCompany.com

Manufactured in the USA since 1881

Assembly Instructions



MODEL 126

BEFORE YOU BEGIN

Unpack contents from the carton and identify each part by reviewing the parts list and photographs. The following tools will be helpful for assembly:

- Hammer
- Slotted screwdriver
- Socket set or wrenches
- Square

STEP #1

Assemble the side and back assemblies so that the smooth sides are on the inside of the Stock Truck. This will make it easier to pile stock and supplies once fully assembled.

The lower shelf has three (3) screw holes in the back flange and two (2) screw holes in the front flange. These holes will match up with two (2) screw holes in the lower front tubular brace.

Two (2) of the four (4) casters have a locking mechanism. You will have to determine whether you want the locking casters on the front or the side of the Stock Truck. In most cases, it will probably work better to have the locking casters on the front.

STEP #2

Lay the back assembly on the floor with the smooth side up, which is the inside of the cart. Stand the left side assembly on edge on the floor and slide it against the left side of the back. The smooth side will be on the inside. The rear channel of the side assembly has the three squares and obround slot cutouts, which now would be toward the floor. Slide the rear caster in the rear tube of the side making sure that the hole in the caster stem lines up with the hole in the rear tube. (See figure #2) Insert the spacer into the rear brace and line up the holes. Insert a 1/4-20 x 2-1/2" machine screw through the rear tube of the side assembly, through the spacer, caster, and through the lower rear tube of the back. Loosely fasten with a 1/4-20 Kepsnut.

Position the lower front brace as shown in figure #2 making certain that the two screw holes in this brace are up, or toward the front. Fasten loosely as above.

Repeat this procedure with the right side and all four casters.

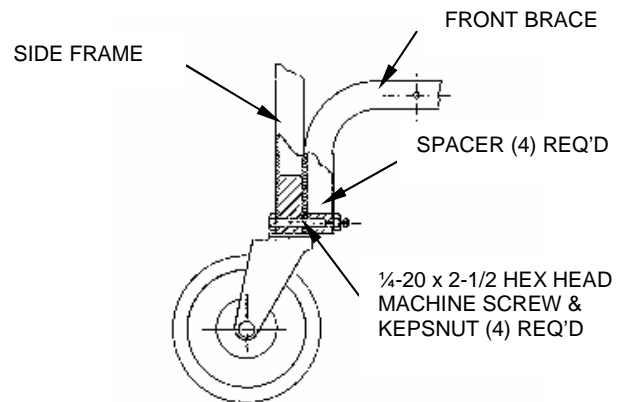

Figure #2

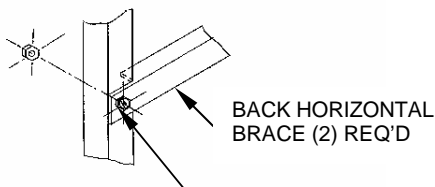

Figure #3

1/4-20 x 1-1/2 HEX HEAD MACH SCREW & KEPSNUT (4) REQ'D

STEP #3

Stand the cart upright on its casters. Refer to figure #3. Insert four (4) 1/4-20 x 1-1/2 machine screws through the back horizontal braces into the rear of the side tubes. Do not tighten nuts.

1/4-20 x 1-1/2 HEX HEAD MACH SCREW. WELD NUT BELOW

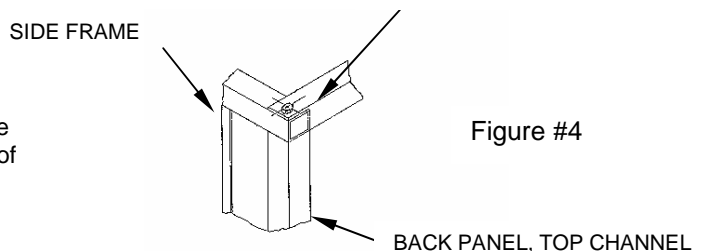

Figure #4

STEP #4

Refer to figure #4. Loosely insert two (2) 1/4-20 x 1-1/2 machine Screws through the top channel of the back panel into the top of the two (2) side assemblies.

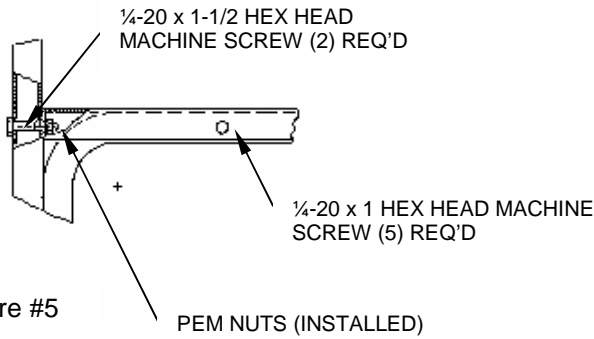

Figure #5

STEP#6

You are now ready to tighten all fasteners, but be sure the cart is square to assure that the center Tilt-A-Way shelves will work freely. We suggest that you use a square and tighten the upper screws first, then the shelf screws, and casters.

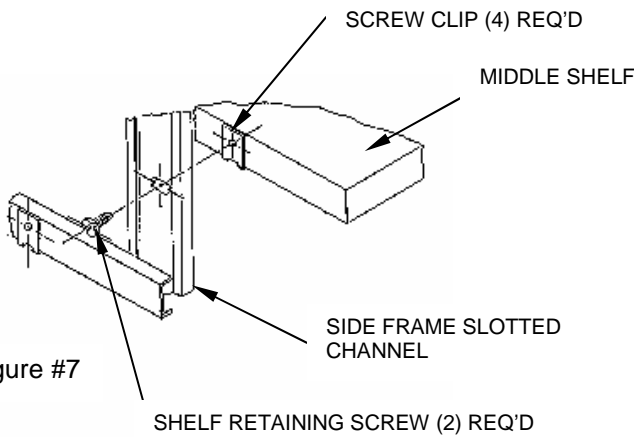

Figure #7

STEP#8

Refer to figures #6 and #8. Attach one shelf corner bracket to the underside of the center shelf as shown in figure #6. Slide the shelf horizontally in place so that the 1/4 x 1" leg of the bracket is in the 1" square cutout, then slide the shelf to the rear so that leg is resting in the rear 1/4 x 1" slot. Loosely insert the two knurled screws through the side frames and into the receptacles on the shelf. This will support the shelf while you slide the second corner bracket in place and fasten it with the 1/4-20 x 1/2 hex head cap screw. The knurled screws can then be tightened by hand pressure only.

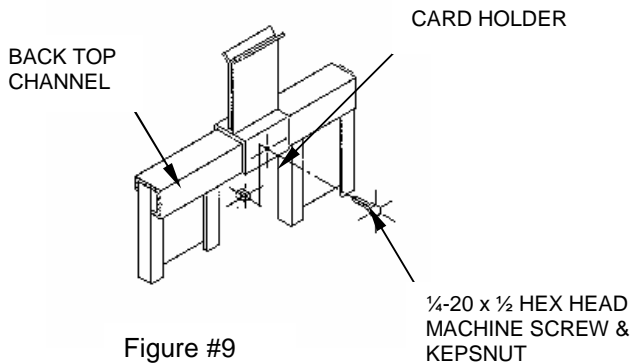

Figure #9

STEP #5

Refer to figure #5. Position the lower shelf as shown, (note: two screw holes in front and three in rear) and loosely install two 1/4-20 x 1-1/2 Hex washer head machine screws into shelf sides and the five 1/4-20 x 1-1/2 Mach screws and Keps nuts front and back.

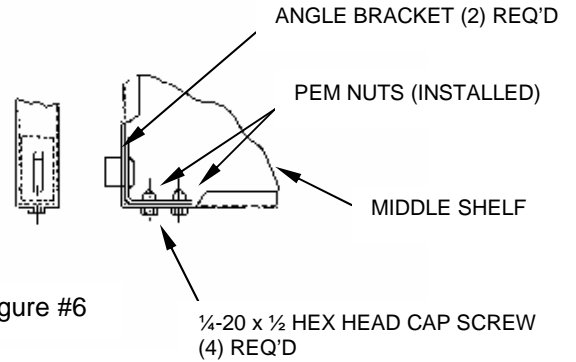

Figure #6

STEP #7

Refer to figures #6 and #7. Using a hammer, gently tap two of the Clip-on receptacles on the center shelf (figure #7) keeping the smooth side of the clip on the outside of the shelf. When properly installed, the clip tends to seat itself in the hole. Attach the other two clips to the horizontal cross channel on each side of the cart for storage of the screws when the shelf is tilted. We will explain this more fully below.

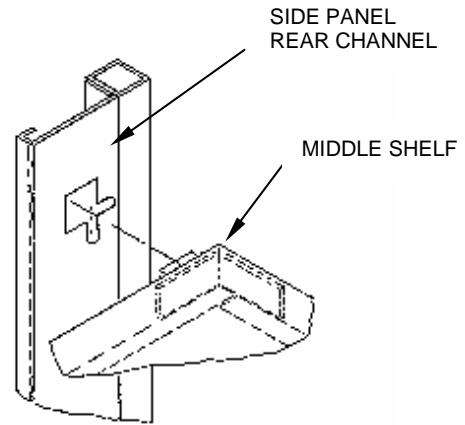

Figure #8

Step #9

Refer to Figure #9. Position the cardholder on the top rail of the back and fasten with a 1/4-20 x 1-1/2 hex head machine screw and Keps nut. Your utility cart is now ready to use.

LIFT UP AND
LOWER

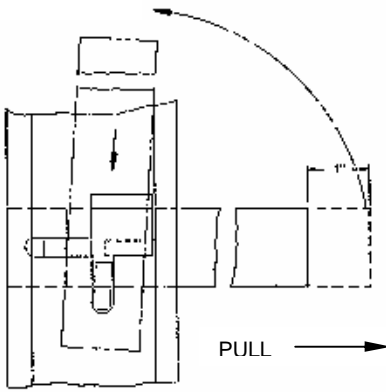

FIGURE #10

THE TILT-A-WAY SHELF FEATURE

We have designed the models 126 and 139 with this exclusive tilt design to allow easier loading of materials from the bottom up. It works like this. As you will notice when the shelf is in its horizontal position and locked in place with the two knurled screws, the 1/4 x 1" legs of the corner brackets are nestled in the rear of the cutout. (Figure #10).

To tilt the shelf, remove the two knurled screws and insert them in the other two storage receptacles on the horizontal cross channels on the side of the cart. Then grasp the shelf with both hands and pull it all the way forward until the 1/4 x 1" legs clear the rear slot. Raise the front of the shelf and push it toward the rear allowing the legs to drop fully into the vertical slot. The shelf will then be locked out of your way for easy loading. Reverse this procedure to lower the shelf into working position.

OPTIONAL SHELVES

Models 126 and 139 have the lower shelf and one Tilt-A-Way shelf as standard equipment. An additional pair of Tilt-A-Way shelves can be ordered as options if your usage requires. Each optional pair of shelves contain the necessary hardware, such as Knurled screws, clip-on receptacles, corner brackets, nuts and bolts, **Order Part #126-A-002** or **139-A-002** for these optional pair of shelves.

We suggest that you retain this assembly instructions and parts list if you need to order repair parts in the future. Rosback also manufactures other models of Utility Stock Trucks and Printing Accessories. Information on these can be obtained from your dealer or Rosback sales department.

We also have the capability of manufacturing custom material handling equipment for your special needs. We will be pleased to offer quotes as needed.

UTILITY STOCK TRUCKS

Parts List

| Part No. | Description | Model 126 | Model 139 |
|-----------|--|-----------|-----------|
| 126-2724 | 126/139 Rt. Side Frame Assembly | 1 | 1 |
| 126-2725 | 126/139 Lt. Side Frame Assembly | 1 | 1 |
| 126-2735 | 126 Back Assembly | 1 | - |
| 136-2754 | 139 Back Assembly | - | 1 |
| 126-A-002 | 126 Shelves (pair) | 2 | - |
| 139-A-002 | 139 Shelves (pair) | - | 2 |
| 126-2743 | 126 Frt. Lower Tubular Brace | 1 | - |
| 139-2758 | 139 Frt. Lower Tubular Brace | - | 1 |
| 126-2742 | Shelf Corner Brackets | 2 | 2 |
| 126-2759 | Card Holders | 1 | 1 |
| 140-2636 | Casters | 2 | 2 |
| 140-2635 | Casters w/Brakes | 2 | 2 |
| 126-13104 | Knurled Head Screws | 2 | 2 |
| 126-10017 | Clip On Receptacles | 4 | 4 |
| STD | 1/4-20 x 2-1/2 Hex Washer Hd Cap Screw | 4 | 4 |
| STD | 1/4-20 Kepsnuts | 18 | 18 |
| STD | 1/4-20 x 1/2 Hex Washer Hd Cap Screw | 1 | 1 |
| STD | 1/4-20 x 1-1/2 Hex Washer Hd Cap Screw | 13 | 13 |